



www.atpkg.com



AT PACKAGING

SALES  SERVICE



TP502MV

SEMI-AUTOMATIC VERTICAL PALLET STRAPPING MACHINE

All of the advantages from TP502, such as compact strapping head, direct drive technology with German-made DC motors, and electronic tension control. The TP502MV provides an ergonomic and cost-effective solution for low volume vertical pallet strapping applications.

STANDARD FEATURES:

- Compact mechanical strapping head
- Electronic tension control
- Jog switch
- Mobility
- Good for lower height pallet
- Adjustable weld-cooling time

OPTION:

- Battery power supply (TP-502MVB)

DIMENSIONS (MM):

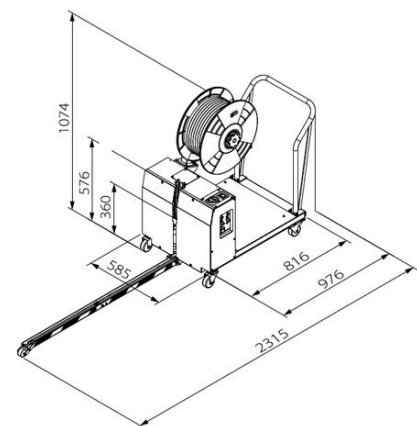

TP502MVB – (BATTERY OPTION)

