



www.atpkg.com



# AT PACKAGING

SALES  SERVICE

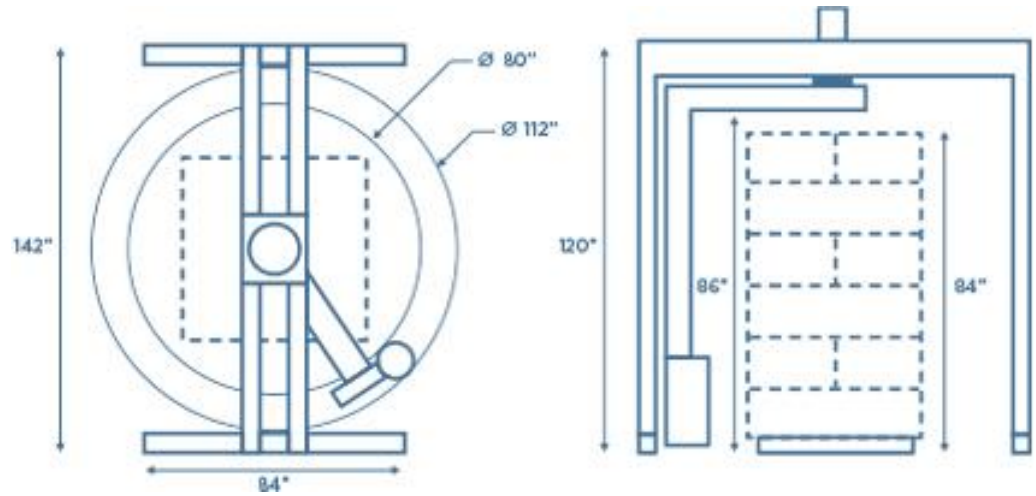

# STAB-L-IZE™ 360°

## SEMI-AUTOMATIC ROTARY TOWER

### TECHNICAL SPECIFICATIONS

Tower Speed	Adjustable up to 16 RPM
Control Type	Full-Feature Semi-Automatic
Max. Load Height	84"
Max. Load Diameter	76"
Pre-Stretch Ratio	250% standard
Max. Load Size	54" x 54"
Electrical	115/1/60 15 amp
Warranty	3/5 years
Options	Wrap height extension for taller pallets Platform scale with digital weight indicator 30" film carriage Safety guarding around wrap zone Auto film cut Arm speed increase



*All dimensions are approximate.*