



www.atpkg.com



DCPRV2PCL

STAB-L-IZE™

TECHNICAL SHEET

- Strapping head with advanced automatic cleaning and lubrication technology for Polypropylene or Polyester strapping.
- Strapping 5/8 or 3/4 optional. (Strapping machine set on 3/4 also accept a 5/8 strapping)
- Automatic use in vertical strapping with welding on the top of the package.
- Strapping feed and pull back controlled by encoder combined with brake motor.
- Strap tension controlled by motor-reducer and VFD. The tension value is adjustable from the terminal.
- Thermo-fusion welding technology.
- Automatic centralized oiling of the strapping head.
- Strapping head automatic dust cleaning device. Activated at every cycle.
- Mechanically welded main frame, heavy duty structure, support for the up-down pressing frame and the lateral jog frame.
- Machine-welded up-down compression frame, heavy duty structure, support for the strapping head. Guided with 2 rails and 4 ball bearings.
- Activated by two hydraulic cylinders and synchronized by two gears mounted on a shaft with two rack and pinions. The compression is adjustable from the dialogue terminal to a maximum tension of 22,480 lbs. Anti-fall protection for the moving part is automatically activated when your staff intervene in the safety zone. A hinged support system allows easy access or removal of the strapping head.

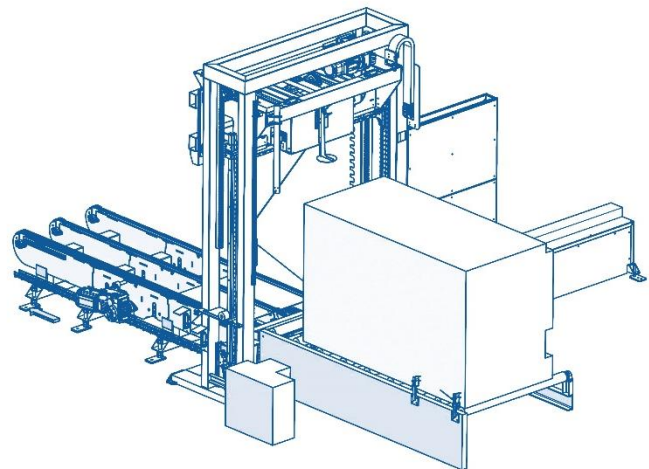
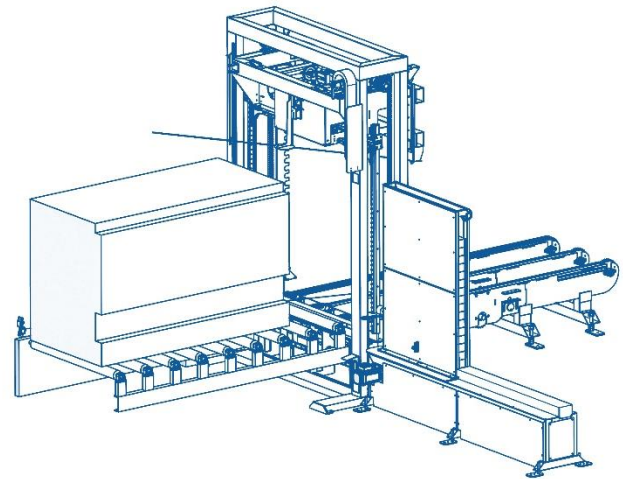

- Mechanically welded lateral frame, heavy duty structure, support for the two mobile right and left compression devices. They are guided by 2 rails and 4 ball bearings.
 - Activated by two hydraulic cylinders and synchronized by two gears mounted on a shaft with two rack and pinions. Lateral compression is adjustable from the dialogue terminal to a maximum tension of 22,480 lbs.
 - The strap feeding system adapts automatically to the heights of the bundles.
 - Track opening system to allow insertion of the rafter.
 - System raises and lowers the rafter under the package, consisting of two mechanical pushers guided by rails and ball bearings and activated by two pneumatic cylinders.
 - Standard motorized dispenser for 16 inch core rolls of strapping.
 - Electrical cabinet includes SIEMENS controls and dialogue terminal allowing the monitoring of the strapping machine assembly and the conveyor supplying the rafters. ETHERNET communication allowing remote program modifications* included.
- * Customer must provide high speed internet access.

OPTIONS

- De-stacking device per rafter layer.
- Superior Cardboard insertion.
- Rafter centering device (for variable lengths).

