



www.atpkg.com



AT PACKAGING

SALES  SERVICE

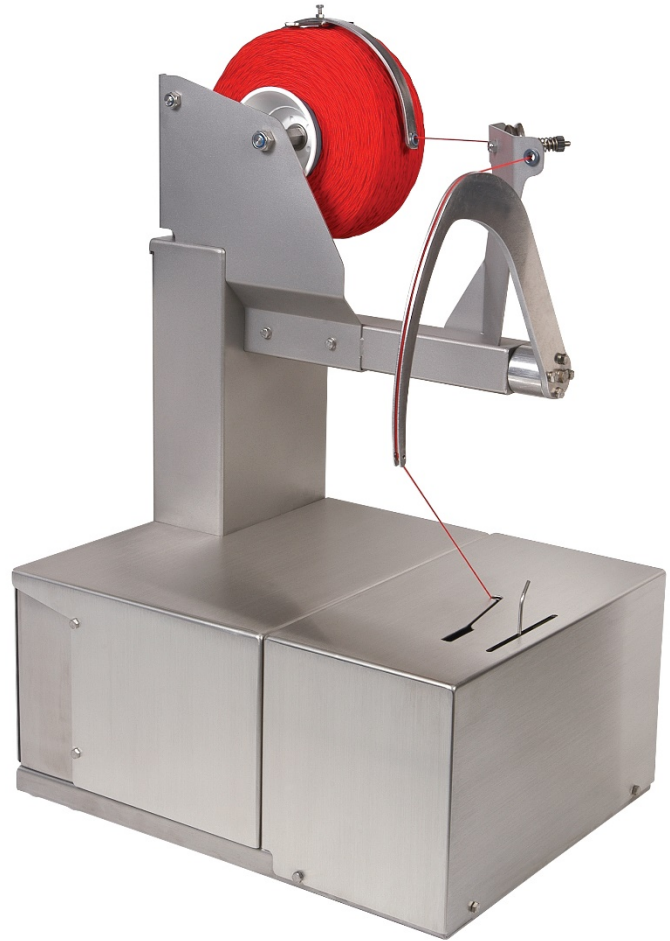
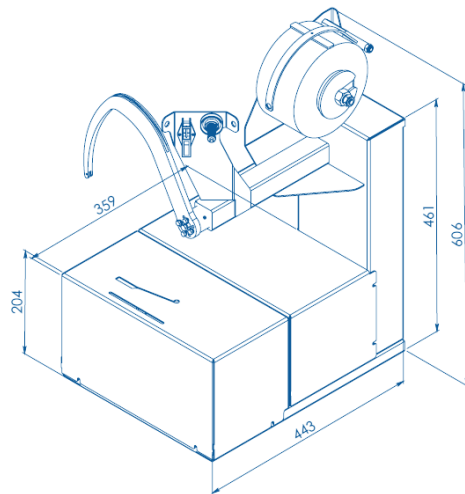

SSB

STANDARD FEATURES:

- Uses calibrated food-grade elastic twine
 - Make knots without diameter restriction of the product
 - Binds without damaging the product
 - Binds properly without wasting string thanks to its patented system
 - The "SSB" can be used as a semi-automatic machine or integrated into a packaging line
 - The "SSB" is the most advanced product in this field and benefits from improved quality, performance, reliability and ease of use.
- Food-grade stainless steel. Easy to clean
 - Binds properly without wasting string thanks to its new patented system
 - Weight: 38.5 kg
 - Power supply:
 - 100/110 VAC single phase
 - 230 VAC single phase
 - Knotting time: 0.44 s
 - Compatible with UL/CSA standards