



www.atpkg.com



AT PACKAGING

SALES  SERVICE

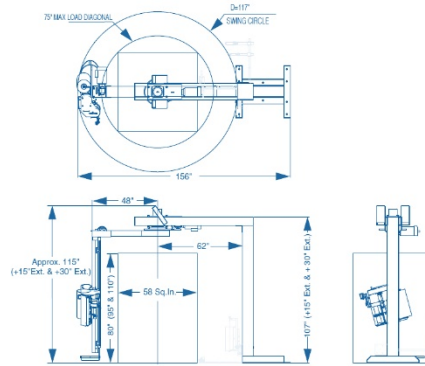

RTA ROTARY TOWER

Maximizes Efficiency by Automating Wrapping Cycle

FEATURES:

- 16 RPM Variable Speed Tower
- Automatic Film Tail Attach/Cut/Press
- Start Cycle With Hanging Lanyard
- No Maximum Load Weight Capacity
- High Performance Film Delivery Carriage
- Floor Mounted Control Panel for Flexibility
- Precision Ring Bearing Drive System
- AC/VFD Motors for Reduced Maintenance
- Structural Steel Construction for Durability
- Heavy Duty Chain & Sprocket Drive
- Tower Mounted Obstacle Sensing System

PRODUCTION SPEED:

- Up to 40-50 loads per hour

MAXIMUM LOAD SIZE:

- 48"W x 48"L x 80"H (68" Diagonal)

InstaThread FILM DELIVERY SYSTEM:

- Film roll: 20" Standard - 30" Optional - 10" Diameter
- Standard prestretch ratio: 260% (higher available)
- Wrap to within 3" of floor
- Automatic load height sensing photoeye
- Automatic film force-to-load control

SHIPPING WEIGHT:

- 2,500+ lbs. (Varies with options)

WARRANTY:

- 4 Years on ALL major components
- 5 Years on structural frame

UTILITIES:

- 115/1/60, 20 Amp electrical service
- 80 PSI @ 3 CFM compressed air

