

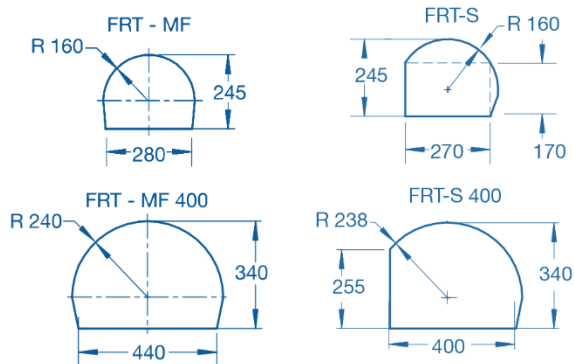

www.atpkg.com

**TUNNEL DIMENTIONS:**



# FRT

**STANDARD FEATURES:**

- Wear-free AC Servomotors
- Automatic reset of knotting unit and ring
- Smart Motion Controller with LED displays
- Up to 63 strings/ min.
- Selector switch for 1, 2, 3, 4, cross and continuous tying
- Larger bobbin reduces downtime for twine changeovers
- Interlocked removable catch tray prevents deposits, residues or product-scrap soiling the floor or the inside of the machine

**SPECIFICATIONS:**

- Connected load: 170 - 260 V, AC, 50/60 Hz, 1.3kW
- Sound pressure level: 72 dB (A) +/- 1
- Weight: FRT-MF & FRT-S = 160 Kg  
FRT-MF400 & FRT-S400 = 165 Kg

